

Master Control Unit

According to system specification no.

620995

Release : - 5 -

1 GENERAL DESCRIPTION

1.1 Illustration

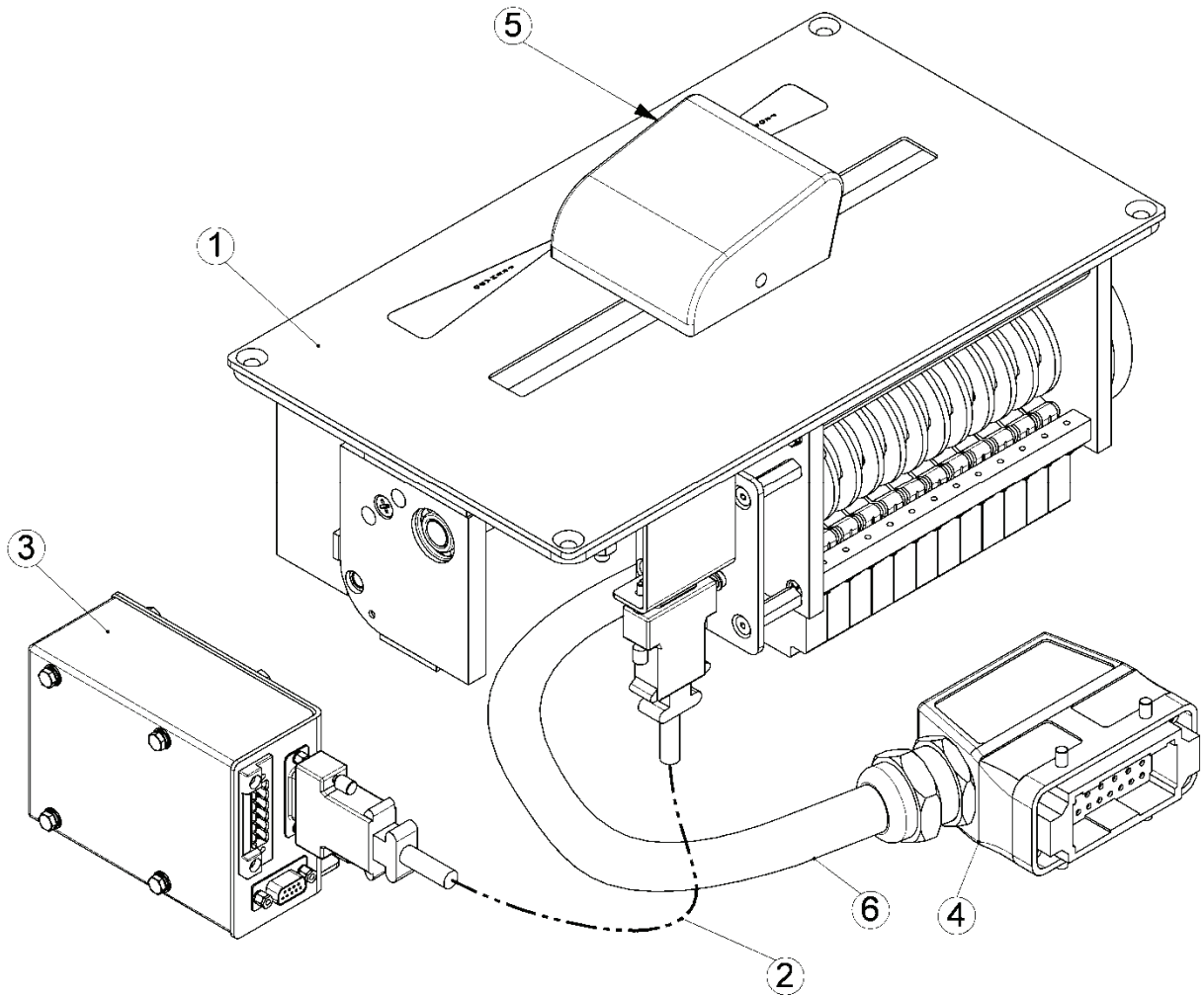

Figure 1: Master Control Unit

1.2 Brief Description

The whole Master Control unit (see Figure 1) is installed in the driver's console and includes the following operating main elements)

- A Power / brake control unit **(1)**
- One connecting cable installed between Power- / brake controller and interface module **(2)**
- An interface module **(3)**
- An capacitive sensor for automatic vigilance control (deadman function) **(5)**

The outline drawing no M 4416 informs about component arrangement and dimensions of the power- / brake control unit which is to be operated by means of a customer specified grip. This grip consists of blank aluminum without any surface treatment. As enlightens from these documents all snap action switches are wired up to a connector **(4)** that is located at the end of flexible connecting cable **(6)**. A strain relief makes sure that the connecting cable is properly fixed to the power-/ brake control unit. The length of the flexible connecting cable can be adapted according to the project specific requirements. The appropriate mating connector, is included in the scope of delivery.

A special connecting cable **(2)** provides the electrical connection between the capacitive sensor, the potentiometers (which are part of the power- / brake controller) and the interface module **(3)** that incorporates the following functions:

- A 72V to 24V DC/DC converter
- Two independent 4 – 20 mA output devices
- The output device of the capacitive sensor which is used for automatic vigilance control (deadman system)

Technical data**Power- / brake control unit**

dimensions	acc. to M 4416
mechanical durability	5 Mio. operating cycles
weight.....	approx 10 Kg
operating temperature range	-25 to +70 °C
maximum humidity during operation	95%
Type tested according to	EN50155
Including:	
Shock- and vibration test according to	IEC 61373
EMC test according to	EN 50 121-3-2