

Driver seat KFS 11



The crane driver`s seat KFS 11 is ergonomically designed and provides a high grade of comfort. The driver`s seat is a low level mechanical suspension seat with an oil-hydraulic vibration absorption system with weight adjustment. All adjustment controls are positioned ergonomically within easy access. The metal parts are protected against corrosion and painted black.

Technical data

Suspension stroke	80 mm
Weight adjustment	50 - 150 kg
Horizontal adjustment	200 mm
Inclination of the backrest	-12°/+40°
Slope adjustment	-10°/+12°
Height adjustment	65 mm



Example

	KFS 11	-A1	-S1
Driver seat			
KFS 11	Driver seat with textile cover black		
Attachments			
K	Headrest		
A1	Armrest adjustable (2 pieces) 50 mm wide		
A2	Armrest continuously adjustable (2 pieces) 100 mm wide		
H	Seat cushion and backrest with heating element 24V DC 75W		
S1	Safety belt 2 point fixing (automatic)		
S3	Safety belt 2 point fixing (static)		
LK	Plate for horizontal manual adjustment of seat adjustable +/-250 mm		
C4	Loose cover for driver seat KFS 11 / KFS 12		
U	Console (base)		

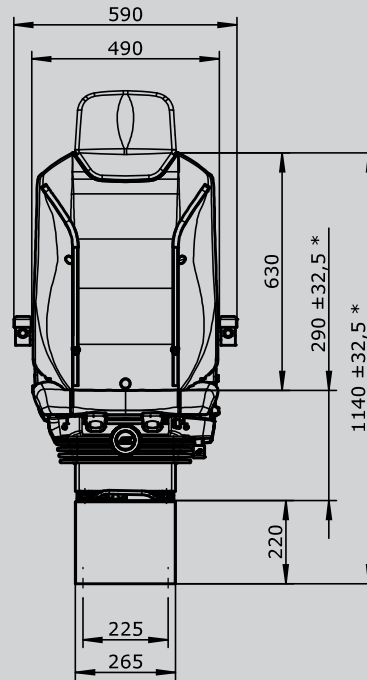
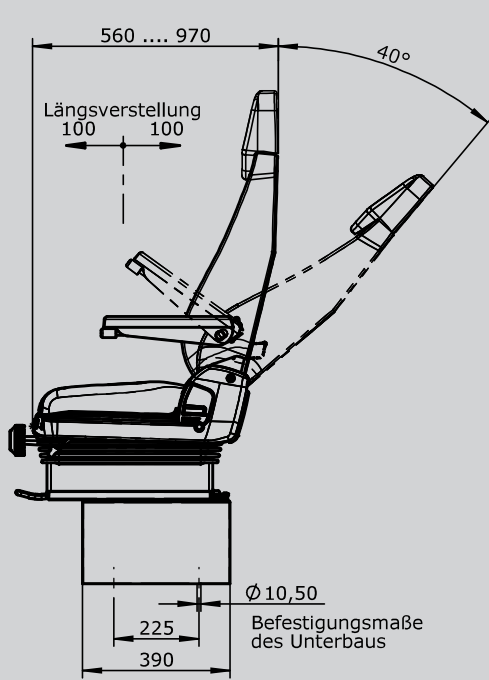

Sonderausführung

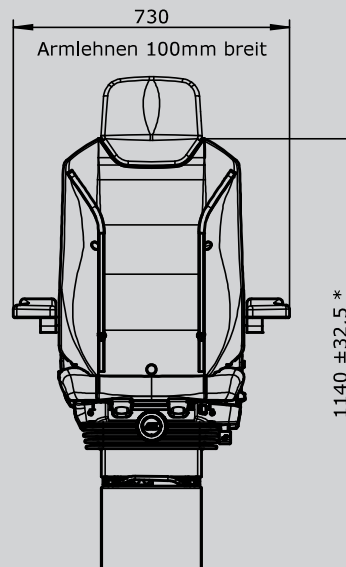
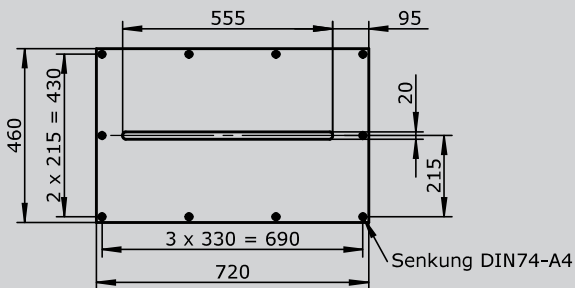
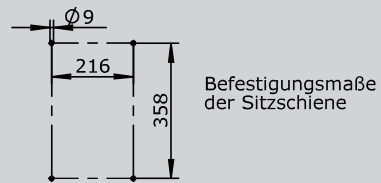
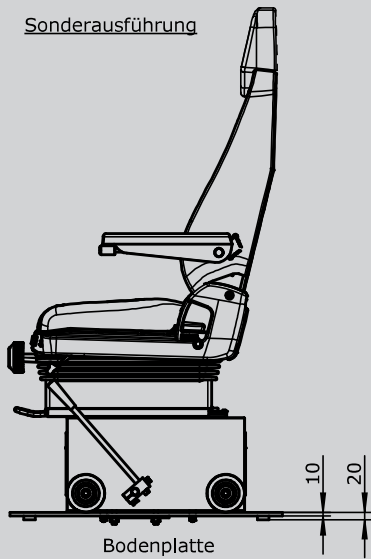

* einstellbar