

Double-handle controller D85



The double-handle controller D85 is a robust switching device for hoisting applications. The modular design enables the switching device to be used universally. The double-handle controller is resistant to oil, maritime conditions e.g. offshore /vessels, UV radiation typically from the sun.



Technical data

Mechanical life D85	8 million operating cycles
Operation temperature	-40°C to +85°C
Degree of protection	IP54 front

1

	D85	S5	Q / Q	-Z	+R	-B	-E...	-S..	-X
Basic unit									
D85									
Control-handle extended									
Standard 160 mm*									
S5 -20 mm									
S8 +20 mm									
<i>*Only available in combination with handle!</i>									
Grip- control-handle left									
Knob									
M Mechanical zero interlock									
T Dead man									
H Signal button									
D Push button									
Q T-grip									
QD T-grip with push button side									
B10... Palm grip B10... (see page 197)									
Grip- control-handle right									
<i>See grip-control-handle left</i>									
Axis 1: direction 1-2 left									
Z Spring return									
R Friction brake									
Axis 2: direction 3-4 left									
Z Spring return									
R Friction brake									

Technical details may vary based on configuration or application! Technical data subject to change without notice!

D85 S5 Q / Q -Z +R -B -E... -S... -X

Cover housing

B Cover housing

Interface (description see following pages)

E1xx Voltage output
 E2xx Current output
 E3xx CAN-interface
 E4xx CANOpen Safety
 E5xx Profibus DP interface
 E6xx Profinet
 E7xx Profinet safe
 E8xx PWM output
 E9xx Other outputs

Plug connectors

S.. Standard plug connectors (see page 138)

Special model

X Special/ customer specified

Combination possibilities with our handles



Digital output

Supply voltage	9-32 V DC
Current carrying capacity	Direction signal 150 mA Zero position signal 500 mA
Mounting depth A	85 mm
Wiring	Cable 500mm long without plug connector Optional with plug connector (standard plug connectors see page 138)
2 direction signals + 1 zero position signal (galvanically isolated) per axis	
	2 axis E001 2

Voltage output (not stabilized)

Supply voltage	4,75-5,25 V DC
Current carrying capacity	Direction signal 8 mA
Mounting depth A	85 mm
Wiring	Cable 500 mm long without plug connector Optional with plug connector (standard plug connectors see page 138)
0,5...2,5...4,5V redundant + 2 direction signals per axis	
	2 Achsen E104 2
Output options	
Characteristic:	
Inverse dual	1
Dual	2
Inverse dual with dead zone +/- 3° (standard)	3
Dual with dead zone +/- 3°	4



Voltage output			
Supply voltage	9-32 V DC (*11,5-32)		
Current carrying capacity	Direction signal 150 mA		
	Zero position signal 500 mA		
Mounting depth A	85 mm		
Wiring	Cable 500 mm long without plug connector		
	Optional with plug connector (<i>standard plug connectors see page 138</i>)		S
0,5...2,5...4,5 V redundant + 2 direction signals + 1 zero position signal (galvanically isolated) per axis			
	2 axis	E112 2	
0...5...10 V redundant + 2 direction signals + 1 zero position signal (galvanically isolated) per axis, supply voltage 11,5 - 32 V DC			
	2 axis	E132 2	
10...0...10 V + 2 direction signals + 1 zero position signal (galvanically isolated) per axis, supply voltage 11,5 - 32 V DC, sensor redundant with error monitoring and error signal			
	2 axis	E136 2	
10...0...10 V + 2 direction signals + 1 zero position signal (galvanically isolated) per axis, supply voltage 11,5 - 32 V DC, sensor redundant with error monitoring			
	2 axis	E138 2	
Output options			
Characteristic:			
	Inverse dual *1		1
	Dual *1		2
	Inverse dual with dead zone +/- 3° *1 (standard)		3
	Dual with dead zone +/- 3° *1		4
*1 not combinable with output E136X and E138X			
	Single *2		5
	Single with dead zone +/- 3° *2 (standard)		6
*2 not combinable with output E112X and E132X			
Digital output signals:			
Output signals standard:			
	Direction signals and zero position signals 1,5A 24 V DC		1

Voltage output with other value on request!

Current output

Supply voltage	9-32 V DC	
Current carrying capacity	Direction signal 150 mA	
	Zero position signal 500 mA	
Mounting depth A	85 mm	
Wiring	Cable 500 mm long without plug connector	
	Optional with plug connector (<i>standard plug connectors see page 138</i>)	
0...10...20 mA + 2 direction signals + 1 zero position signal (galvanically isolated) per axis, sensor redundant with error monitoring and error signal		
	2 axis	E206 2
20...0...20 mA + 2 direction signals + 1 zero position signal (galvanically isolated) per axis, sensor redundant with error monitoring and error signal		
	2 axis	E208 2
4...12...20 mA + 2 direction signals + 1 zero position signal (galvanically isolated) per axis, sensor redundant with error monitoring and error signal		
	2 axis	E214 2
20...4...20 mA + 2 direction signals + 1 zero position signal (galvanically isolated) per axis, sensor redundant with error monitoring and error signal		
	2 axis	E216 2
+20...0...-20 mA + 2 direction signals + 1 zero position signal (galvanically isolated) per axis, sensor redundant with error monitoring and error signal		
	2 axis	E226 2
Output options		
	Single	5
	Single with dead zone +/- 3° (standard)	6
Digital output signals:		
Output signals standard:		
	Direction signals and zero position signals 1,5A 24 V DC	1

Current output with other value on request!

CAN

Supply voltage	9-36 V DC	
Idle current consumption	120 mA	
Current carrying capacity	Direction signal 100 mA	
	Zero position signal 100 mA	
	External digital output for LEDs 5-30 mA (dependent on the number of LED`s)	
	Digital switching output (potential-free) 100 mA	
Mounting depth A	E3091: 85 mm	
	E3091X: 105 mm	
	E3101X - E3103X: 105 mm	
	E3104X - E3105X: 125 mm	
Protocol	CANOpen CiA DS 301 or SAE J 1939	
Baud rate	125 kBit/s to 1 Mbit/s (standard 250 kBit/s)	
Output value	255...0...255	
Wiring	CAN (IN) cable 300 mm with plug connector M12 (male)	
	CAN (OUT) cable 300 mm with plug connector M12 (female)	
	External in-/outputs cable 300 mm without plug connector	
	External in-/outputs cable 300 mm without plug connector (additionally from 32 in-/outputs)	

Optional with plug connector (*standard plug connectors see page 138*)

S

CAN expansion stage 1

E309 1

- 7 analoge Joystickachsen
- 16 digitale Joystickfunktionen
- Input for capacitive sensor

With additional external in-/outputs

- 8 external LED-outputs (dimnable optional), 1 switching output (potential-free, 100 mA), 8 external digital inputs
- 16 external LED-outputs (dimnable optional), 1 switching output (potential-free, 100 mA), 16* external digital inputs

2

3

External LED-outputs can be used in the grip for LEDs

**With the use of capacitive sensor, the external digital inputs reduce by one input!*

CAN expansion stage 2

E310 1

- 10 analog joystick axis
- 16 digital joystick functions
- 2 inputs for capacitive sensor

With additional external in-/outputs

- 8 external LED-outputs (dimnable optional), 1 switching output (potential-free, 100 mA), 8 external digital inputs
- 16 external LED-outputs (dimnable optional), 1 switching output (potential-free, 100 mA), 16* external digital inputs
- 24 external LED-outputs (dimnable optional), 1 switching output (potential-free, 100 mA), 24 external digital inputs
- 32 external LED-outputs (dimnable optional), 1 switching output (potential-free, 100 mA), 32* external digital inputs

2

3

4

5

External LED-outputs can be used in the grip for LEDs

**With the use of capacitive sensor, the external digital inputs reduce by one input!*

Main-axis with additional digital-/analog outputs separately wired (not via CAN)

- 2 direction signals + 1 zero position signal (potential-free) per main-axis

Additional analog outputs on request!

CANopen Safety

Supply voltage	9-36 V DC
Idle current consumption	120 mA
Current carrying capacity	Direction signal 100 mA Zero position signal 100 mA External digital output for LEDs 5-30 mA (depending on the number of LED`s) Digital switching output (potential-free) 100 mA
Mounting depth A	E4091: 85 mm E4091X: 105 mm E4101X - E4103X: 105 mm E4104X - E4105X: 125 mm
Protocol	CAN Safety CIA 304
Baud rate	125 kBit/s to 1 MBit/s (Standard 250 kBits)
Output value	255...0...255
Wiring	CAN (IN) cable 300 mm with plug connector M12 (male) CAN (OUT) cable 300 mm with plug connector M12 (female) External in-/outputs cable 300 mm without plug connector External in-/outputs cable 300 mm without plug connector (additionally from 32 in-/outputs)

Optional with plug connector (<i>standard plug connectors see page 138</i>)		S
CANOpen safety expansion stage 1		E409 1
<ul style="list-style-type: none"> - 7 analog joystick axis - 16 digital joystick functions - Input for capacitive sensor 		
With additional external in-/outputs		
- 8 external LED-outputs (dimmable optional), 1 switching output (potential-free, 100 mA), 8 external digital inputs		2
- 16 external LED-outputs (dimmable optional), 1 switching output (potential-free, 100 mA), 16* external digital inputs		3
<i>External LED-outputs can be used in the grip for LEDs</i>		
<i>*With the use of capacitive sensor, the external digital inputs reduce by one input!</i>		
CANOpen safety expansion stage 2		E410 1
<ul style="list-style-type: none"> - 10 analog joystick axis - 16 digital joystick functions 		
With additional external in-/outputs		
- 8 external LED-outputs (dimmable optional), 1 switching output (potential-free, 100 mA), 8 external digital inputs		2
- 16 external LED-outputs (dimmable optional), 1 switching output (potential-free, 100 mA), 16* external digital inputs		3
- 24 external LED-outputs (dimmable optional), 1 switching output (potential-free, 100 mA), 24 external digital inputs		4
- 32 external LED-outputs (dimmable optional), 1 switching output (potential-free, 100 mA), 32* external digital inputs		5
<i>External LED-outputs can be used in the grip for LEDs</i>		
<i>*With the use of capacitive sensor, the external digital inputs reduce by one input!</i>		
Main-axis with additional digital-/analog outputs separately wired (not via CAN)		
- 2 direction signals + 1 zero position signal (potential-free) per main-axis		3
<i>Additional analog outputs on request!</i>		



Profibus DP		S
Supply voltage	18-30 V DC	
Baud rate	to 12 MBit/s	
Output value	0...128...255	
Mounting depth A	105 mm	
Wiring	Profibus, cable 100 mm with plug D-Sub 9	
	Supply voltage (if applicable contact wiring) cable 12 x 0,25 mm ² 300 mm long without plug connector	
	External in-/outputs, cable 300 mm long without plug connector	
Optional with plug connector (<i>standard plug connectors see page 138</i>)		S
Profibus DP		E501 1
<ul style="list-style-type: none"> - 4 analog joystick axis - 16 digital joystick function - Input for capacitive sensor 		
With additional external in-/outputs		
- 8 external LED-output, 8 external digital input		2
- 16 external LED-output, 16 external digital input		3
<i>External LED-outputs can be used in the grip for LEDs</i>		
With additional contact equipment separately wired (not via profibus)		
- 2 direction contacts + 1 zero position contact (not potential-free) per main-axis		1
- 1 zero position contact (potential-free) per main-axis		2

1

Profinet			
Supply voltage	18-30 V DC		
Baud rate	to 100 MBit/s		
Output value	0...512...1023		
Mounting depth A	105 mm		
Verdrahtung	Profinet (1), cable 300 mm with M12 plug connector (female) Profinet (2), cable 300 mm with M12 plug connector (female) Supply voltage (if applicable contact wiring) cable 12 x 0,25 mm ² 300 mm long without plug connector External in-/outputs, cable 300 mm long without plug connector		
	Optional with plug connector (<i>standard plug connectors see page 138</i>)		S
Profinet		E601 1	
- 4 analog joystick axis			
- 16 digital joystick functions			
- Input for capacitive sensor			
With additional external in-/outputs			
- 8 external LED-outputs, 8 external digital inputs		2	
- 16 external LED-outputs, 16 external digital inputs		3	
<i>*External LED-outputs can be used in the grip for LEDs</i>			
Main-axis with additional signals separately wired (not via profinet)			
- 2 direction signals + zero position signal (potential-free) per main-axis			3

Profinet Safe			
Supply voltage	18-30 V DC		
Baud rate	to 12 MBit/s		
Output value	0...512...1023		
Mounting depth A	105 mm		
Wiring	Profinet (1), cable 300 mm with M12 plug connector (female) Profinet (2), cable 300 mm with M12 plug connector (female) Supply voltage (if applicable contact wiring) cable 12 x 0,25 mm ² 300 mm long without plug connector External in-/outputs, cable 300 mm long without plug connector		
	Optional with plug connector (<i>standard plug connectors see page 138</i>)		S
- 4 analog joystick axis		E701 1	
- 16 digital joystick functions			
- Input for capacitive sensor			
With additional external in-/outputs			
- 8 external LED-outputs, 8 external digital inputs		2	
- 16 external LED-outputs, 16 external digital inputs		3	
<i>*External LED-outputs can be used in the grip for LEDs</i>			
Main-axis with additional signals separately wired (not via profinet safe)			
- 2 direction signals + zero position signal (potential-free) per main-axis			3

PWM Outputs

Supply Voltage:	9-32V DC		
Valve control current:	max. 3 A		
PWM-frequency:	1225 Hz		
Dither frequency:	1...250 Hz adjustable		
Mounting depth A	85 mm		
Other features	Creep speed per axis 5 configurable switching outputs 2A LED outputs for status indication Input for redundant deadman		
Wiring:	Built-in socket Phoenix 2-pole (power supply) Cable 1 (PWM) 12 x 1mm ² 300 mm long without plug Cable 2 (switching output) 12 x 1mm ² 300 mm long without plug Cable 3 (creep speed / dead man) 14x0,25mm ² 300mm long without plug Optional with plug connector (<i>standard plug connectors see page 138</i>)		
PWM Output 0-3 A for 2 proportional valve magnets per axis	1 axis	E801 1	S
	2 axis	2	
	3 axis	3	
	4 axis	4	

Other outputs

Voltage output for PVG32 0,25...0,5...0,75 Us, power supply 9-32 V DC			
Wiring:	Cable 14 x 0,25 mm ² 300 mm long without plug connector Optional with plug connector (<i>standard plug connectors see page 138</i>)		
	2 axis	E907 2	S
Main-axis with additional direction contacts per main-axis			4
8 Bit Gray-Code with direction signals per main-axis, supply voltage 9-36 V DC			
Wiring:	Cable 37 x 0,14 mm ² 300 mm long without plug connector (axis 1+2) Optional with plug connector (<i>standard plug connectors see page 138</i>)		
	2 axis	E903 2	S
8 Bit Binär-Code with direction signals per main-axis, supply voltage 9-36 V DC			
Wiring:	Cable 37 x 0,14 mm ² 300 mm long without plug connector (axis 1+2) Optional with plug connector (<i>standard plug connectors see page 138</i>)		
	2 axis	E904 2	S

Attachments

Z01 Mating connector (CAN) M12 (male insert) with 2 m cable	20201140
Z02 Mating connector (CAN) M12 (female contact) with 2 m cable	20202298
Z03 Mating connector (Profibus) straight	22201440
Z04 Mating connector (Profibus) 90° angled	22201741
Z05 Mating connector (Profinet) M12 (male insert) with 2 m cable	5300000222

T = Dead man's button
H = Signal button

Knob solid
D= Push button

T - grip
D= Push button

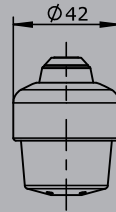
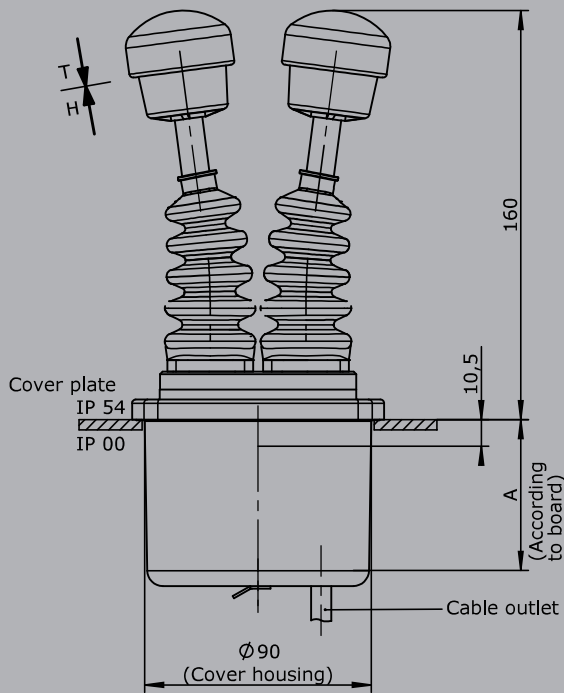

To build in:
Direction 1-2
Direction 3-4

