

Single-axis controller S14



The single-axis controller S14 is a designed hall sensor switching device for electro-hydraulic and remote controlled hydraulic. The modular design of the switching device is universally applicable. The single-axis controller is resistant to oil, maritime conditions e.g. offshore /vessels, UV radiation typically from the sun.



Technical data

Mechanical life S14	6 million operating cycles
Operating temperature	-40°C to +85°C
Degree of protection	up to IP65

	S14L	S8	Example T	-01ZC	-A05 C61	-X
Basic unit						
S14L						
Control-handle extended						
Standard 60 mm*						
S8 +20 mm						
<i>*Only possible in combination with handle!</i>						
Grip / palm grip						
T Dead man						
Axis 1 (direction 1-2)						
O1 2 contacts (2A 250 V AC15)						
Z Spring return						
C Mechanical encoder						
Description axis 1 (direction 1-2)						
A05 Arrangement MSP21						
C61 Mechanical encoder MEC 1-2						
Special model						
X Special / customer specified						

	S14L	S8	T	-01ZC	-A05 C61	-X
Basic unit						
S14L 1-axis left						
S14R 1-axis right						
Control-handle extended						
Standard 60 mm*						
S8 +20 mm						
<i>*Only possible in combination with handle!</i>						
Grip / palm grip						
Knob (standard)						
M Mechanical zero interlock						
MH Mechanical zero interlock + signal contact						
T Dead man						
H Signal button						
GK1 Knob 42 mm						
GK1M Mechanical zero interlock						

Identification of the installation variants with switching directions:

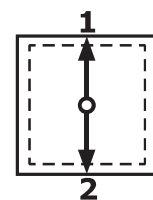

S14

Technical details may vary based on configuration or application! Technical data subject to change without notice!

S14L S8 T -01ZC -A05 C61 -X

GK1MN	Mechanical zero interlock (push down)
GK1T	Dead man
GK1H	Signal button
GK1MH	Mechanical zero interlock + signal contact
GK1D	Push button
GK1DV	Flush push button
GS9	Hall-twist grip with spring return
GS9-D	Hall-twist grip with spring return and push button on top
B ...	Palm grip B... <i>(on request!)</i>

S14L S8 T -01ZC -A05 C61 -X

Axis 1: direction 1-2 left / direction 5-6 right

(Standard contacts gold-plated 2A 250V AC15)

01	2 contacts	Standard contact - arrangement see page 140
02	4 contacts	z.B.
03	6 contacts	A05 MS21 A0500 MS21-00 A110 MS24-0 <i>A99 contact - arrangement according customer request</i>

Z Spring return *(included in basic unit!)*

R Friction brake

C Mechanical encoder

C61	MEC 1-2	
	EA/02-10	I max. 1 mA
	Potentiometer track	2 x 10 kOhm
	Direction track	Arrangement MS26-0
C62	MEC 1-7	
	EA/10-10	I max. 1 mA
	Potentiometer track	2 x 5 kOhm
	Direction track	Arrangement MS26-0-1
C66	MEC 1-10	
	EA/17-10	I max. 1 mA
	Potentiometer track	2 x 1,5 kOhm
	Direction track	Arrangement MS21-0+MS21
C63	MEC 1-6	
	EA/09-10	
	6 Bit Gray Code	
C64	MEC 1-6-5	
	ER/36-10	Us= 18-30 V
	Current output 20...4...20 mA	
C65	MEC 1-6-8	
	ER/ 36-10	Us= 18-30 V
	Current output 20...0...20 mA	
C67	MEC 1-6-9	
	ER/36-11	Us= 18-30 V
	Voltage output 10...0...10V	

More potentiometers on request!

H	Hall-Potentiometer	E14811	0,5...2,5...5,4 V / 4,5...2,5...0,5 V
---	--------------------	--------	---------------------------------------

S14L S8 T -01ZC -A05 C61 -X

Special model

X	Special / customer specified
---	------------------------------



1

T = Dead man's button
H = Signal button
M = Latch for mechanical zero interlock

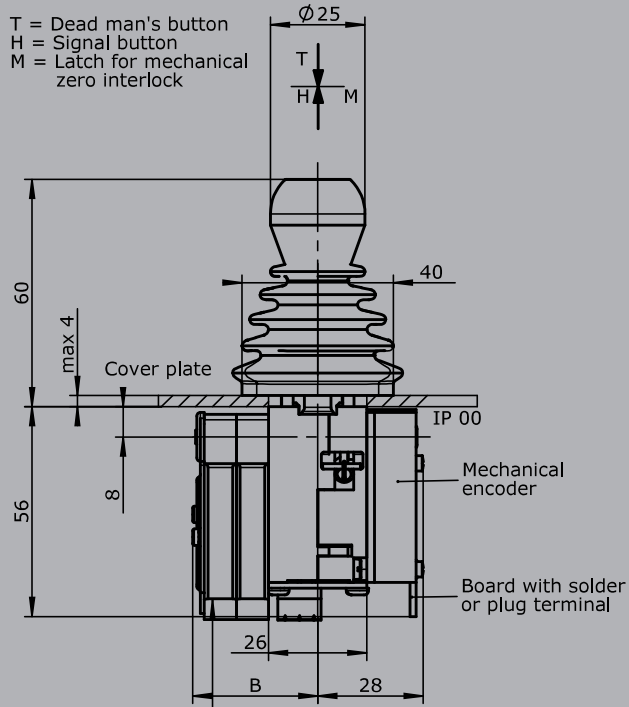

CAGE CLAMP® connection
max. 1,5mm²

Knob solid GK
for MN, MP

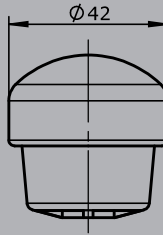

Twist grip

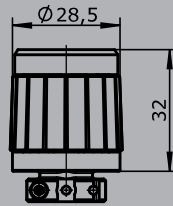

Twist grip
with Push button

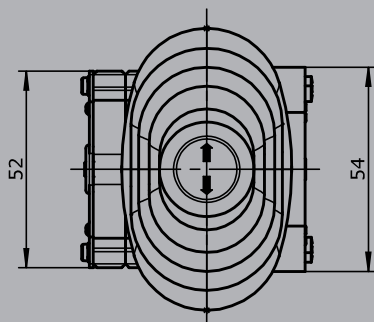
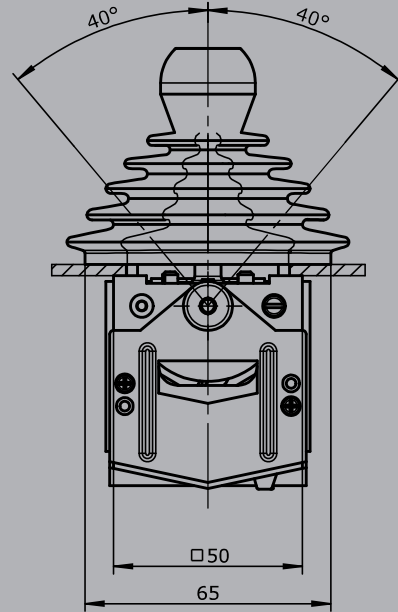
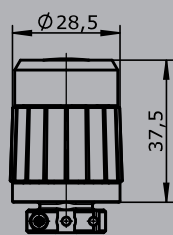

Hole pattern

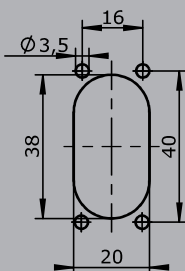

Type	No. of contacts	Dim. B
01	2	24
02	4	33
03	6	42